

# INSTALLATION

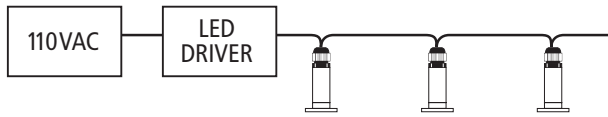

Determine where you wish the LED MiniDisc Light to be placed.

1. Drill a 1.0" diameter hole into mounting surface. LED MiniDisc Lights will require a hole of at least 3-1/2" long x 1.0" diameter. If you wish to recess the cover of the LED MiniDisc Light for a totally flush mount, you will need to center drill an additional 2.0" diameter hole, 5/32" deep. Note that an 18 gauge wire will also have to pass from LED Driver to all LED MiniDisc Lights.
2. Place LED MiniDisc Lights loosely into holes, do not mount at this time.
3. Locate LED Driver adjacent to 110VAC. Remember, 100 LED MiniDisc Lights maximum per LED Driver. Leave LED Driver unattached to 110VAC power.
4. Use only 18G wire of the following specifications:
  - For all applications with wire interior to a wall, use only UL listed 18G wire labeled "CL2", NSL part number LW-18G-CL2.
  - For all outdoor or burial applications, use only UL listed 18G wire labeled "Sprinkler Wire" or "Direct Burial", NSL part number LW-18G-BUR.

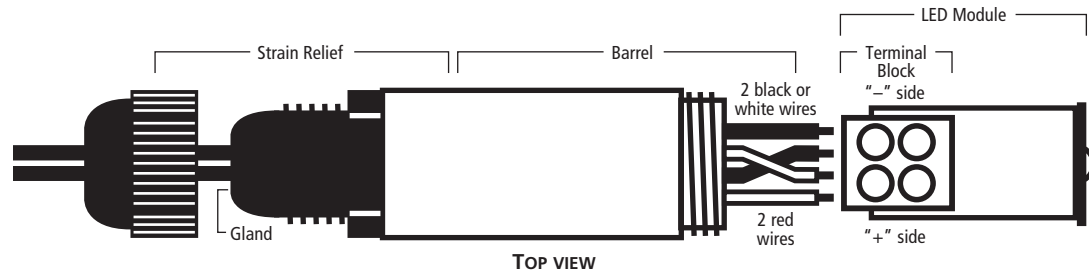

5. Disassemble LED MiniDisc Light per diagram below. Bring power wire from LED Driver to LED MiniDisc Lights and strip insulation off of the wire leaving 3/8" of bare copper wire.
6. Bring both the incoming power wire, and the outgoing power wire, into the LED MiniDisc Light strain relief by pushing each through the respective hole in strain relief rubber gland. If you encounter difficulty inserting wire into the gland, apply a small amount of Vaseline on the outside of the wire. Once through the strain relief gland, separate the incoming and outgoing power wires into two sets of black or white, and two sets of red wires. See diagram above.
7. Note polarity in terminal block. Attach both black or white wires to the "-" side. Attach both red wires to the "+" side. Tighten terminal block screws. See diagram above.
8. Pull wires and LED module into LED MiniDisc Light barrel until LED module is flush with top of barrel. Screw on cover firmly. Tighten strain relief nut firmly.

**VERY IMPORTANT! TO PROPERLY TIGHTEN THE BLACK PLASTIC STRAIN RELIEF NUT, FIRST TIGHTEN FIRMLY WITH YOUR HAND, THEN TIGHTEN AN ADDITIONAL ONE-HALF TURN WITH A 7/8" OPEN END WRENCH.**

9. On the last LED MiniDisc Light in the run, you will only have one incoming power wire, no outgoing power wire. On this LED MiniDisc Light place the incoming power wire through one hole in the strain relief, and in the other hole place acrylic rod included with this instruction sheet.
10. Bring power wire from first LED MiniDisc Light through a proper strain relief, and into the LED Driver. Note polarity. Place black or white power wire into "-" side, and red power wire into "+" side of LED Driver output.
11. Assure all connections and strain reliefs are firmly tightened, cover is tight on LED Driver, and then hard wire LED Driver to 110VAC.
12. LED MiniDisc Light will illuminate in about 3 seconds. If all do not illuminate, check connections and polarity at the LED Driver. If one does not illuminate, check connections and polarity at the unlit LED MiniDisc Light.
13. With system working properly, attach LED MiniDisc Lights to mounting surface by securing mounting screws provided through LED MiniDisc Light cover and into mounting surface.

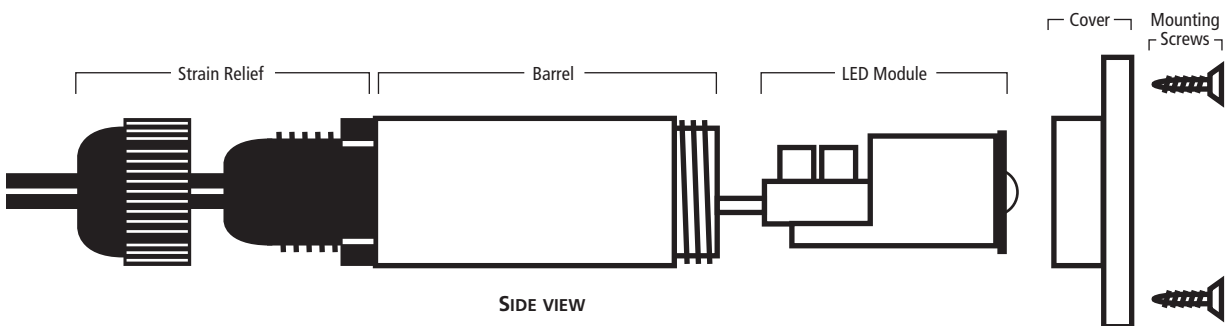

## WARNING

To reduce the risk of fire, electrical shock, or injury to persons:

1. Use only with our UL Listed LED Class 2 Driver, LEDDR-12-60W.
2. Parallel wire LED MiniDisc Lights to LED Driver.
3. Use only 18G wire of the following specifications:
  - For all applications with wire interior to a wall, use only UL listed 18G wire labeled "CL2", NSL part number LW-18G-CL2.
  - For all outdoor or burial applications, use only UL listed 18G wire labeled "Sprinkler Wire" or "Direct Burial", NSL part number LW-18G-BUR.
4. First, make sure LED Driver is not receiving power in any way. Wire LED MiniDisc Lights per these instructions, assure proper tightness on all terminal blocks, strain reliefs, and MiniDisc Light covers, and **then** apply 110VAC power to LED Driver.
5. Do not try to adjust, fix, rewire, LED module. In the unlikely event LED module does not illuminate, check wiring polarity and terminal block first. If this does not work, send LED module back for warranty replacement, if applicable.
6. Not for use with dimmers.

**NOTE:** These products may represent a possible shock or fire hazard if improperly installed or attached in any way. Products should be installed in accordance with the owner's manual, current local codes, and/or the current National Electrical Code (NEC).

## SPECIFICATIONS

Voltage:	UL Listed with our LED Driver, LEDDR-12-60W
Electrical Rating Per MiniDisc Light:	0.54 watts, 44mA, 12VDC
Max. MiniDisc Lights Per Run:	100 MiniDisc Lights per 60 watt LED Driver
Average LED Life:	60,000 hours
Finish Options:	Natural Aluminum, Black, White, Bronze, Stainless Steel
Lens:	Frosted
UL Listing:	UL Listed for wet and burial applications

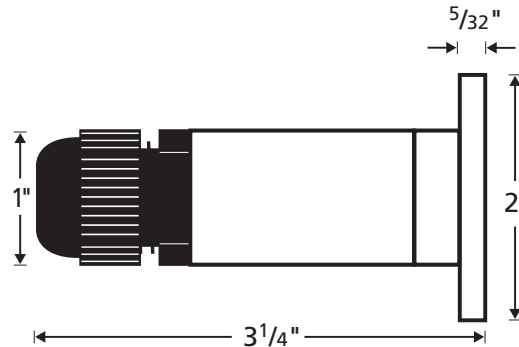

## INSTALLATION INSTRUCTIONS

# LED MINIDISC LIGHT

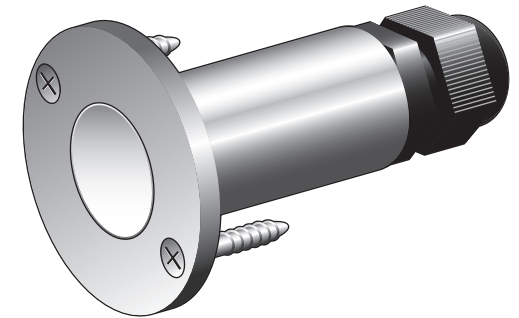

## APPLICATIONS

Steps  
Aisles  
Paths  
Driveways  
Direction Lighting  
Information Lighting  
Decorative Lighting  
Merchandising  
Landscape Accents

## NATIONAL SPECIALTY LIGHTING

ARCHITECTURAL AND DECORATIVE LIGHTING

LOUISVILLE, CO 80027

[www.nslusa.com](http://www.nslusa.com)

© 2011 National Specialty Lighting

**NSL**  
NATIONAL SPECIALTY LIGHTING

**UL** US  
LISTED  
Wet, IC and Direct  
Burial Locations

# LED MINIDISC LIGHT

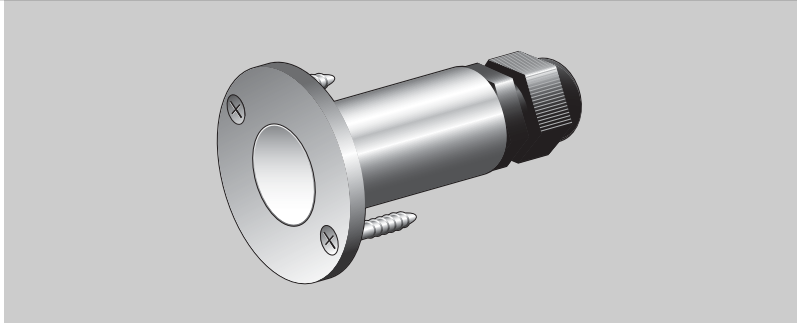

## 100% LED LIGHT OUTPUT CHART

With every foot of lead wire, and every light fixture, there is voltage loss. With too much voltage loss, all light fixtures will not develop 100% of their potential output. Below is a chart of acceptable voltage loss which will maintain 100% of the potential light output of the LED MiniDisc Light. Simply plot the

number of MiniDiscs you wish to place on one lead on the horizontal axis, with the total distance from the LED Driver to the last LED MiniDisc on the vertical axis. If the resulting plot is at or below the line shown, you will have acceptable voltage loss and your LED MiniDisc will output 100% of their

potential. Please note that this is per lead, and you have the option of up to three leads from the LED Driver. In any of the three leads, if your plot is below the line shown, you have acceptable voltage loss. The only limitation is that you may place no more than 100 MiniDiscs on any one LED Driver.

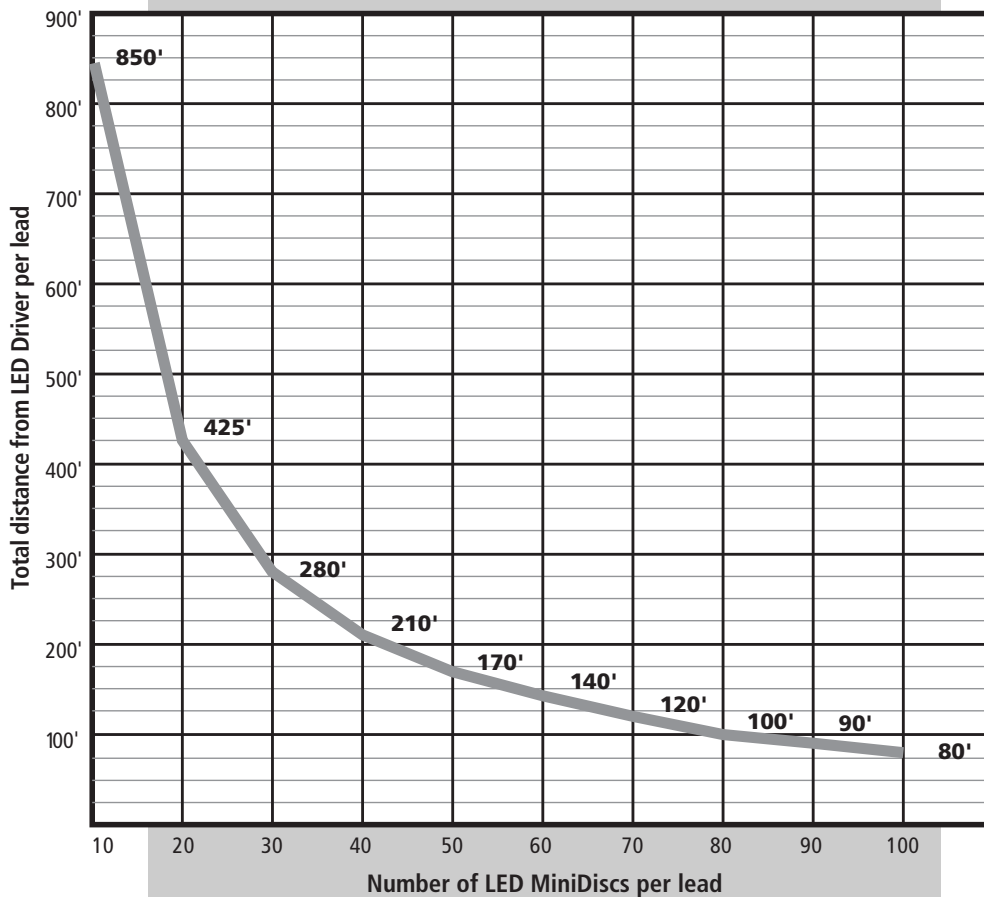

**NOTE:** No more than 100 MiniDiscs per LED driver. Each LED driver has the option of three leads.

**NATIONAL SPECIALTY LIGHTING**  
 ARCHITECTURAL AND DECORATIVE LIGHTING  
 LOUISVILLE, CO 80027 · [www.nslusa.com](http://www.nslusa.com)