

MOUNTING AND WIRING INSTRUCTIONS

1. First release glass diffuser lens by pressing metal tabs on each end of the LTL outward. This loosens the glass lens which will swing down.

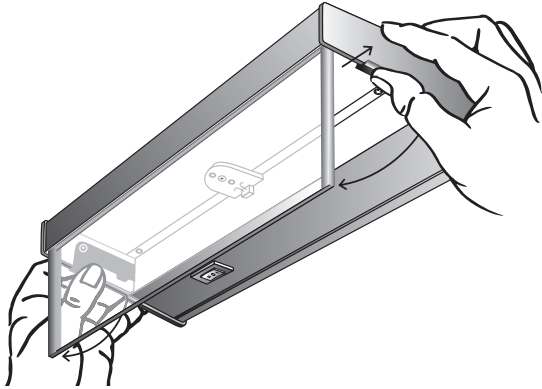

NOTE:

Four and five LED module units have magnet(s) on center of lens which will require a gentle pry downward with a small screwdriver on the lens to release.

2. Easy mounting is assured by simply positioning fixture on mounting surface and driving the two pre-positioned screws into underside of cabinet with a power screwdriver. See below.

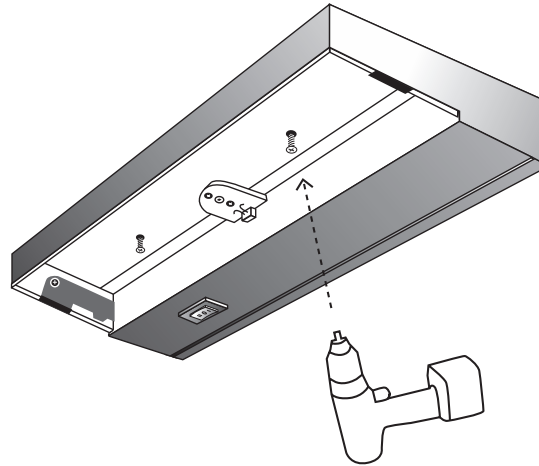

NOTE:

For wall or under cabinet mount only.

CAUTION! Only qualified electricians, or people familiar with household electrical circuits, should bring 110V power to the fixture. Before bringing 110V wire to fixture, make sure incoming wire is not "hot" and all power to wire is off. Not for use with rigid conduit systems. Use flexible conduit to attach to fixture.

3. Through one of the many knockouts provided, bring in 110V power wiring. Secure to fixture with appropriate strain relief.

4. Strip 1/3" (8mm) of the insulation off each incoming 110V power wire. Connect white wire (neutral wire) to push-in connector on white wire from LED Driver. Connect black incoming 110V power wire (hot wire) to push-in connector on black wire from switch. Connect ground wire to push-in connector from ground wire attached to fixture. Push all wires firmly down into connectors, so that uninsulated wire is not exposed.

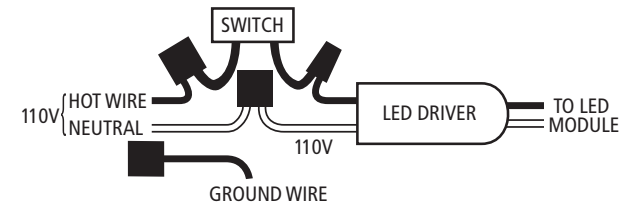

5. Check all connections. Close wiring cover by pushing firmly into fixture until thumb release "clicks" into place. Make sure cover is secure before installing diffuser.
6. Replace glass diffuser by swinging glass lens up into position.
7. Apply 110V power to incoming wiring.
8. Not dimmable.

RELAMPING LED MODULE

In the highly unlikely event of an LED module failure, please follow the instructions listed below:

CAUTION! If unit has recently been operating, glass, LED module(s), and fixture are hot! Turn off fixture and allow it to cool for 15 minutes before relamping.

CAUTION! Always replace LED module(s) with fixture switch in the OFF position.

NOTE: Using a thin pair of gloves during this procedure will eliminate fingerprints on glass lens and LED module(s).

1. Release glass diffuser lens by pressing metal tabs on each end of the LTL outward. This loosens the glass lens which will swing down.
2. Push down on LED module male connector clip. This will disengage connector clip from female connector side in fixture. With connector clip free, gently pull connector apart.
3. Unscrew old LED module. Replace with new LED module (NSL Part No. LEDMOD-12-CR). Tighten screws just snug.
4. Push male connector from LED module into female connector in fixture. Make sure male connector clip engages to female connector.
5. Replace glass diffuser by swinging glass lens up into position.

THROUGH-WIRE, 110V POWER

- Disconnect from all 110V power prior to installation.
- Connections must be made in accordance with all local electric codes and/or NEC.
- Interconnect up to 132 LED modules.
- 14 gauge (Romex Type) or better wire is required.
- Requires strain reliefs.
- Power cord version should not be used for multiple unit wiring.

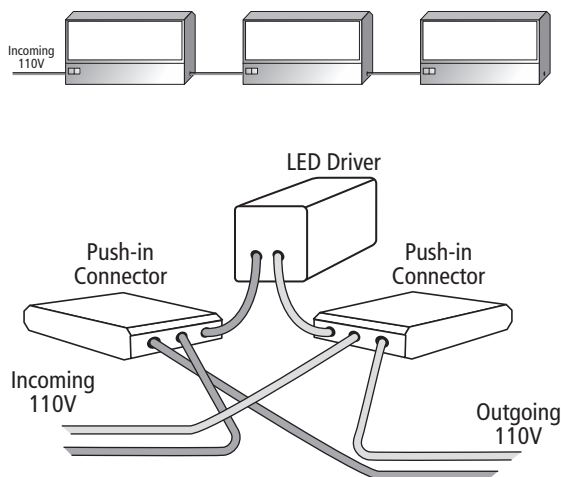

INSTALLATION INSTRUCTIONS

LED TASK LIGHT

Self-Contained LED Task Light Fixture

HARD WIRE VERSION

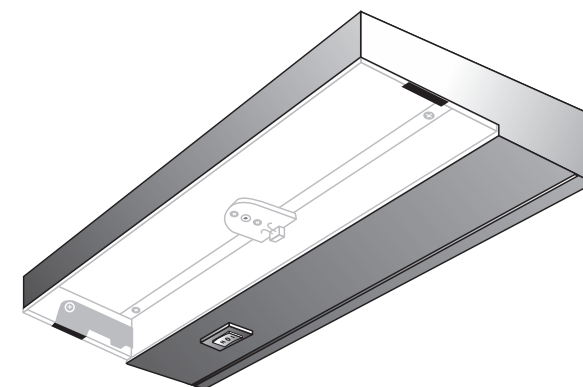

- Under cabinet task light
- Bright enough for writing and detail work
- Integral on/off switch
- Cooler and safer than halogen lights
- 60,000 hour LED life
- Not dimmable

NATIONAL SPECIALTY LIGHTING
ARCHITECTURAL AND DECORATIVE LIGHTING

LOUISVILLE, CO 80027

www.nslusa.com

© 2009 National Specialty Lighting

4/09

NSL
NATIONAL SPECIALTY LIGHTING

