

## MOUNTING AND WIRING INSTRUCTIONS

1. First release glass diffuser lens by unscrewing bolts on either side of lens just enough to release diffuser lens. The glass diffuser lens will swing down. Lens cover will hold bolts in place.

**NOTE:** Four and five LED module units have magnet(s) on center of lens which will require a gentle pry downward with a small screwdriver on the lens to release.

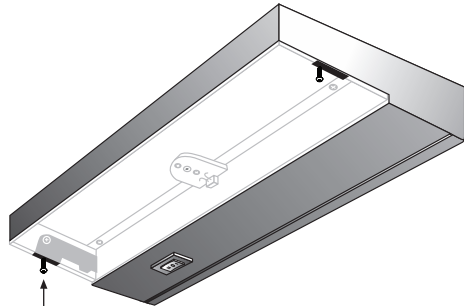

Glass diffuser lens bolts

2. Easy mounting is assured by simply positioning fixture on mounting surface and driving the two prepositioned screws into underside of cabinet with a power screwdriver. See below.

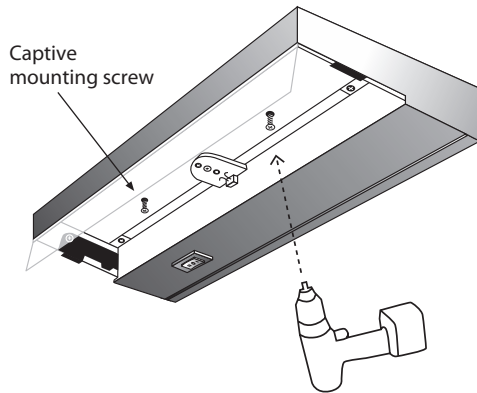

Captive mounting screw

**NOTE:**  
For wall or under cabinet mount only.

**CAUTION!** Only qualified electricians, or people familiar with household electrical circuits, should bring 120VAC power to the fixture. Before bringing 120VAC wire to fixture, make sure incoming wire is not "hot" and all power to wire is off. Not for use with rigid conduit systems. Use flexible conduit to attach to fixture.

3. Open wiring compartment cover by pressing metal tabs on each end of fixture. Wiring compartment cover will swing down.

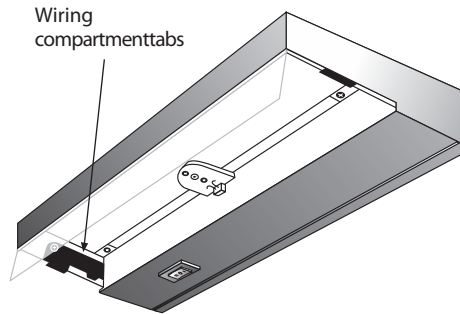

Wiring compartment tabs

4. Through one of the many knockouts provided, bring in 120VAC power wiring. Secure to fixture with appropriate strain relief (not provided).
5. Strip 1/3" (8mm) of the insulation off each incoming 120VAC power wire. Connect white wire (neutral wire) to push-in connector on white wire from rectifier. Connect black incoming 120VAC power wire (hot wire) to push-in connector on black wire from switch. Connect ground wire to push-in connector from ground wire attached to fixture. Push all wires firmly down into connectors, so that uninsulated wire is not exposed.

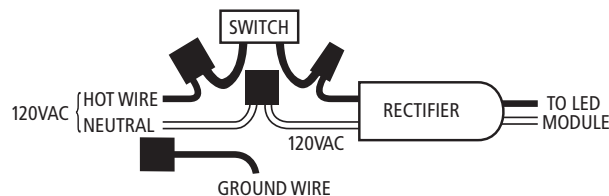

6. Check all connections. Close wiring compartment cover by pushing firmly into fixture until thumb release "clicks" into place.
7. Replace glass diffuser lens by swinging glass lens up into position and tightening lens cover bolts snug.
8. Apply 120VAC power to incoming wire.

## DIMMING

There are two ways at present to dim the LED Task Star:

1. The first option consists of dimmers with forward phase TRIAC design and HED technology. These dimmers tend to be less expensive and have shown very good results. These dimmers also have an advantage of requiring only two wires within the switch box in a single pole configurations (HOT and GROUND). For optimum results these dimmers also have a dimming range adjustment. Maximum load for these dimmers is 150W. Recommended manufacture and model numbers are below:

LUTRON "Skylark" SCL-153P  
LUTRON "Skylark Contour" CTCL-153P  
LUTRON "Diva" DVCL-153P

2. The second option consists of dimmers with 'trailing edge' electronic design. These dimmers have shown slightly more even dimming results and are generally considerably more expensive. Trailing edge dimmers will require the switch box to contain all three wires (HOT, NEUTRAL, and GROUND). Maximum load for these dimmers is 300W. Recommended manufactures and model numbers are:

LUTRON "Skylark" SELV-300P  
LUTRON "Skylark Contour" CTELV-303P  
LUTRON "Diva" DVELV-300P

**Note:** All the specified dimmers will dim down to 5-10%. All specified dimmers also have an integral on/off switch to eliminate any light from the fixtures. Please read and follow dimmer manufacture instructions.

## REPLACEMENT LED ASSEMBLY

In the highly unlikely event of an LED module failure, please follow the instructions listed below:

**CAUTION!** If unit has recently been operating, glass lens and LED module are hot! Turn off fixture and allow it to cool for 15 minutes before relamping.

**CAUTION!** Always replace LED module with all power off to fixture.

**NOTE:** Using a thin pair of gloves during this procedure will eliminate fingerprints on glass lens and LED module.

1. First remove glass diffuser lens by unscrewing two bolts holding glass diffuser lens to fixture.
2. Push down on LED module male connector clip. This will disengage connector clip from female connector side in fixture. With connector clip free, gently pull connector apart.
3. Unscrew old LED module. Replace with new LED module (NSL Part No. LEDMOD-32-FF). Tighten bolts just snug.
4. Push male connector from LED module into female connector in fixture. Make sure male connector clip engages to female connector completely.
5. Replace glass diffuser by swinging glass diffuser lens up into position and tighten bolts snug.

## SCHEMATIC

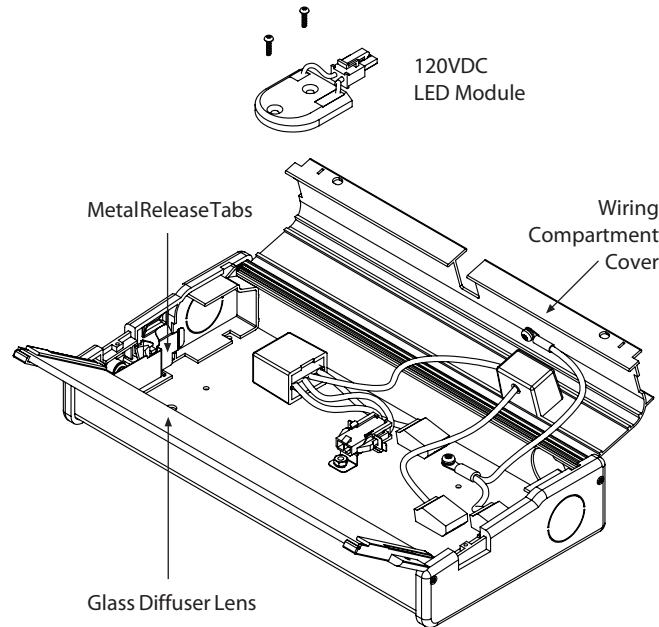

## THROUGH-WIRE, 120VAC POWER

- Disconnect from all 120VAC power prior to installation.
- Connections must be made in accordance with all local electric codes and/or NEC.
- Interconnect up to 150 LED modules without dimmer.
- For maximum load with dimmer, consult dimmer instructions.
- 14 gauge (Romex Type) or better wire is required.
- Requires strain reliefs.

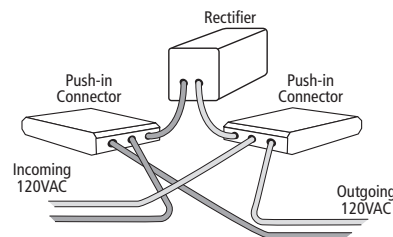

## INSTALLATION INSTRUCTIONS

# LED Task Star

## Self-Contained 120VDC LED Task Light Fixture

### HARD WIRE VERSION

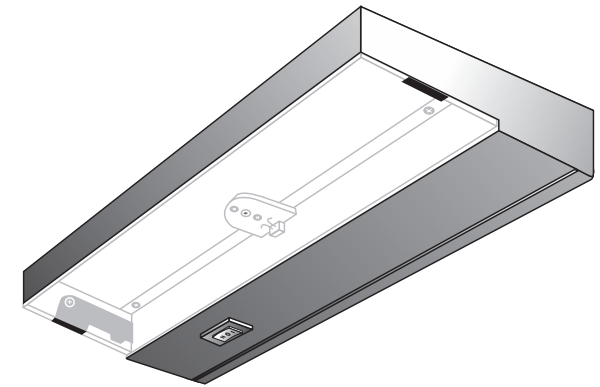

Under cabinet task light

Twice as bright as Halogen/Xenon

Cooler and safer than Halogen lights

Integral on/off switch

40,000 hour rated LED life

Dimmable

**NSL**  
NATIONAL SPECIALTY LIGHTING  
YOUR TRUSTED LIGHTING PARTNER



**NATIONAL SPECIALTY LIGHTING**  
ARCHITECTURAL AND DECORATIVE LIGHTING  
2299 Kenmore Ave, Tonawanda, NY 14207  
[www.nslusa.com](http://www.nslusa.com)