

LED Parking Garage Light

FIXTURE INSTALLATION	LED Parking Garage Light	PG-XXX-40W-aaK
Important: Read all instructions in order to ensure safety and proper installation.		

Wiring Diagram

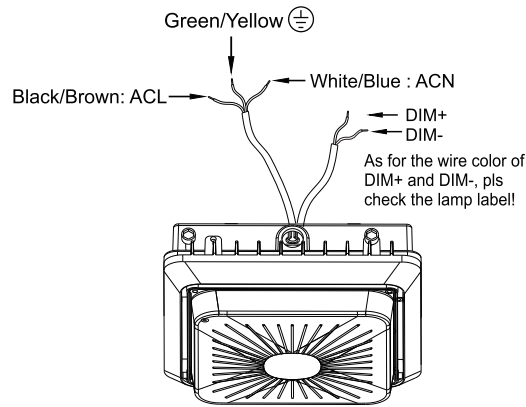

Tools Required



Philips
Screwdriver



Power Drill

MAINTENANCE

- Do not modify this fixture. Any modifications may render the product unsafe and void warranty.

Limited Warranty

The warranty applies to the product from the original date of purchase for five (5) years against manufacturing defects. The owner must provide a copy of the original proof of purchase. The manufacturer's obligation under this warranty is limited to repairing or replacing the component. It is not related in any way to the cost of the connection, the installation of the replacement parts or cost of transport.

INSTALLATION GUIDE

⚠ WARNING

Turn power OFF from electrical panel before installation or maintenance.

Installation Method

1. To remove the metal box cover, loosen the two screws using an Allen Key, then slide horizontally the cover to remove it from hinges. Fig 2-1
2. Loosen the 3/4 plug on the driver box cover using a flat screwdriver. Fig. 2-2
3. Drill the holes on the ceiling accordingly to fit the plate. Fig. 2-3
4. Insert the wires through the plug hole, and mount the cover on the ceiling with screws. Fig.2-4
5. Slide the cover horizontally to attach it to the hinges. Fig. 2-5
6. Connect the input line and ground. If the fixture is equipped with sensor, adjust the sensor settings. Take relevant waterproof measures after the wires are connected. Fig. 2-6
7. Close the box carefully not to cut any wires. Fig. 2-7
8. Tighten the two screws using an Allen key to secure the fixture. Fig. 2-8

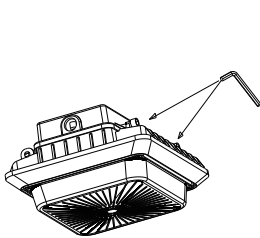

Figure 2-1

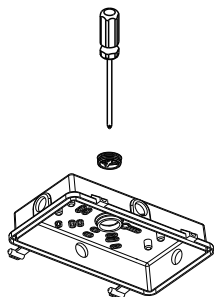

Figure 2-2

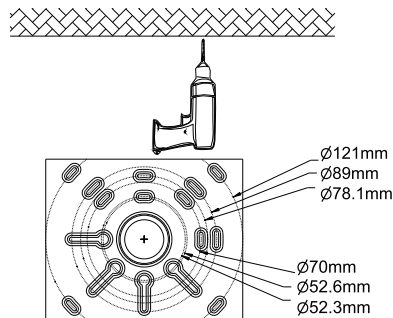

Figure 2-3

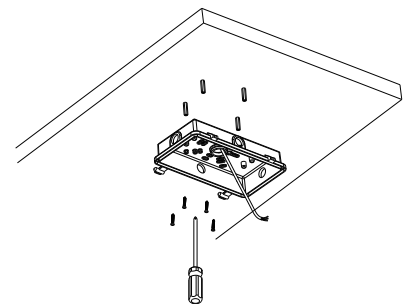

Figure 2-4

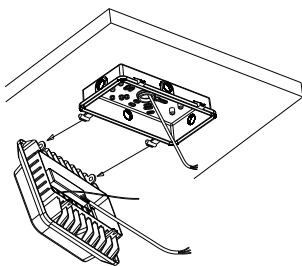

Figure 2-5

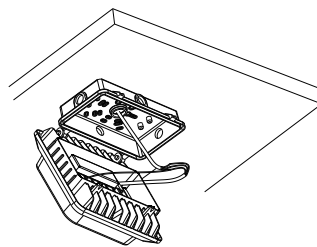

Figure 2-6

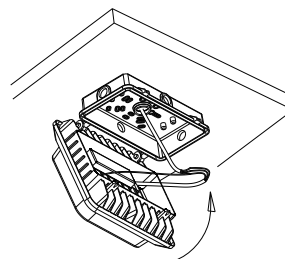

Figure 2-7

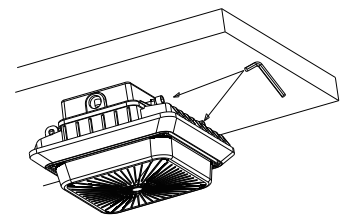

Figure 2-8