

Xenon Step Light

Xenon Step Light provides a safe, attractive and affordable way to light stairs, hallways and aisleways. Xenon Step Light (XSL) comes with an 18 watt xenon lamp. Xenon Step Light is made of die cast aluminum and comes with integral 12 volt transformer and housing for easy installation into walls of any construction.



FEATURES

- Safety - burns significantly cooler than halogen
- Low pressure lamps are safer than halogen
- Easy to re-lamp
- Long life - 10,000 hours
- No harmful UV rays from lamp
- Lamp lumen output 264 lumens
- Fast and easy installation
- cETLus listed for wet locations
- Die cast aluminum construction suitable for concrete pour installations
- 120 volt push in connectors provided for ease of power input
- Bulb replacement has low voltage safety (12 volt class 2 transformer in each fixture)
- Dimmable
- 1 year limited warranty

APPLICATIONS

- Interior stairs
- Exterior stairs
- Aisles
- Hallways
- Paths
- Emergency lighting
- Theaters
- Public areas
- Patios
- Decks

SPECIFICATIONS

Electrical	120V AC, 18W
Wiring Options	120V AC hardwire - can be daisy chained up to 66 fixtures per 15A circuit
LED Life	10,000 hours
Color Temperature	2750K
Replacement Lamp	12V, 18W, product code XTL-BULB
Cover Finish	Powder Coated White, Bronze, Black, Brushed Aluminum
Can Finish	Powder Coated White
Construction	Cover and can cast aluminum
Lens	Frosted Tempered Glass
Cover Dimensions	
Scoop	7 1/2" x 4 5/8" x 1 1/2" (190.5 x 117.5 x 38.1mm)
Prism	7 1/2" x 4 5/8" x 3/4" (190.5 x 117.5 x 19.1mm)
Louver	7 1/2" x 4 5/8" x 3/4" (190.5 x 117.5 x 19.1mm)
Can Dimensions	
Scoop	5 1/2" x 4" x 2 1/2" (139.7 x 101.5 x 63.5mm)
Prism	5 1/2" x 4" x 2 1/2" (139.7 x 101.5 x 63.5mm)
Louver	5 1/2" x 4" x 2 1/2" (139.7 x 101.5 x 63.5mm)
Approvals	cETLus listed for wall, ceiling, wet and IC locations

PRODUCT CODES

XSL - X - YY

Xenon Step Light	COVER TYPE	LED Color
	P - Prism	WH - White
	S - Scoop	BK - Black
	L - Louver	BZ - Bronze
		AL - Aluminum

CONCRETE CAP

SL-CC

Concrete cap for concrete pour installations

NOTE: For outdoor installations, a 1/2" strain relief cord connector is recommended.

ACCESSORIES

XEN-12-18W

18W, 12V Xenon replacement bulb

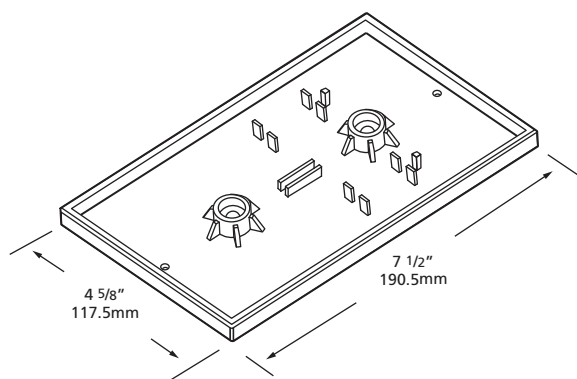
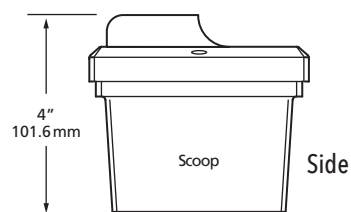
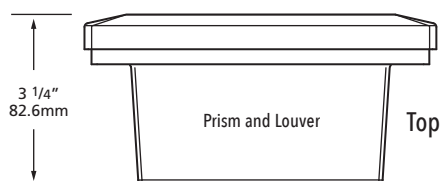
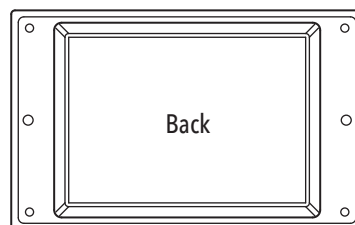
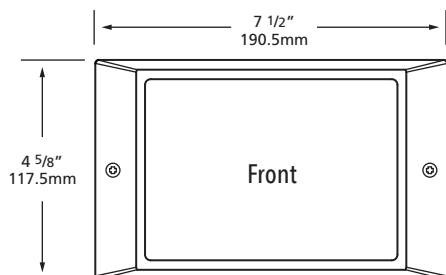

Concrete Cap
for concrete pour installations

Product Code: SL-CC

IMPORTANT: It is recommended that you use National Specialty Lighting's Concrete Cap for concrete pour installations. These caps assist in providing a proper reveal for flush mount of fixture cover after concrete is dry.

ACCESSORIES

XSL-TRANS

Replacement Transformer