



DESCRIPTION

This manual is for NSL's indoor ST and SL series of 24V LED strip lights.

These LED strips are widely used in homes, offices, and commercial spaces where dry conditions prevail. With flexible installation options and a variety of color temperature choices, it offers users an efficient, energy-saving, and long-lasting lighting solution.

APPLICATIONS

1. Lighting for festivals, events, exhibitions, etc
2. Signboard running lights, back lights
3. LED full-color applications
4. Cove/Accent Lighting
5. Perimeter Lighting
6. Under Cabinet Lighting

SPECIFICATIONS

Input Voltage:	DC24V
CCT:	2700K, 3000K, Tunable CCT, RGB
Operating Temperature:	-20°C~40°C
Beam angle:	120°
IP Grade:	IP20-IP40
Warranty:	5 years
LED tests:	LM80
CRI:	CRI>90

STEPS FOR INSTALLATION

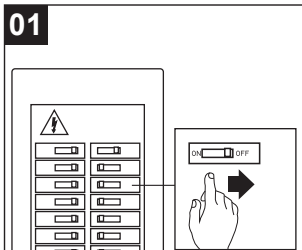

Before installing, please turn off the power supply of the lighting panel circuit.

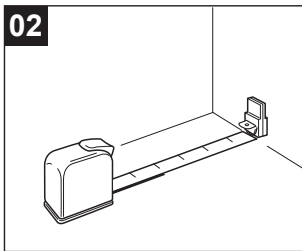

Measure the length of the surface where the LED strip is installed.

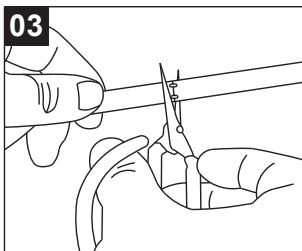

Cut the light strip into the required length. Be sure to use sharp scissors and cut directly on the marked cutting line.

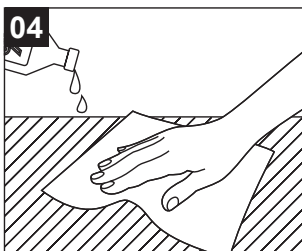

Clean the installation surface and make sure the surface to be installed is smooth and free of any dust or oil stains.

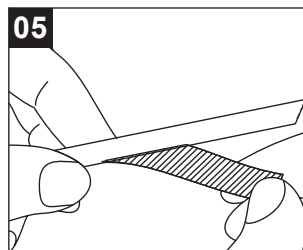

Gently pull off the centrifugal paper of the double-sided adhesive on the back of the LED strip, and stick the light strip to the surface where it needs to be installed.

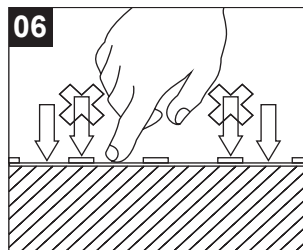

Do not tear off all the centrifugal paper at once. You need to peel and stick it at the same time, and gently press both sides of the PCB to ensure a firm adhesion. Be careful not to press on the LED and other components on the mounting surface.

CONNECTOR INSTALLATION

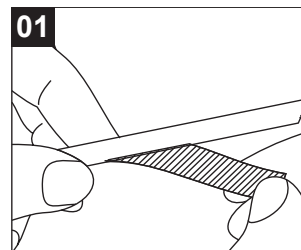

Peel off the adhesive tape at the front end of the cut LED strip.

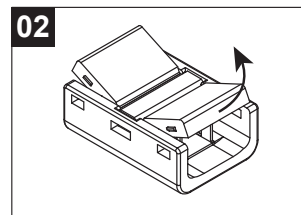

Turn the connector cover upward to 60 degrees.

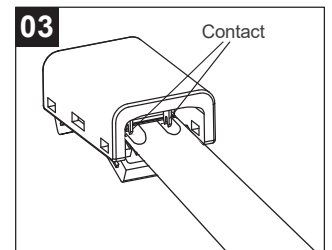

Insert the light strip into the connector, and make sure the LEDs are aligned with the notch with the gap and the positive and negative poles of the light strip, and the cover is pressed tightly to completely lock it with both sides of the socket. You can use tools.

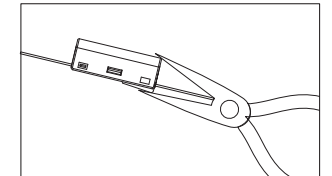

NOTE: For porous surfaces that will not allow a firm grip with the self adhesive backing, we recommend that you use a U channel or appropriate extrusion. Scan QR Code below for more information.

CONNECT LED STRIP TO THE POWER SUPPLY

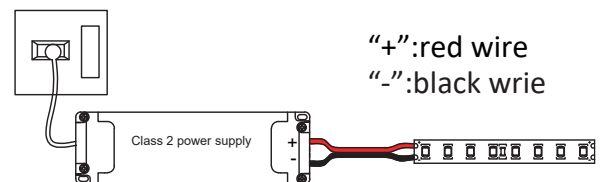

Connect the input wires on the light strip to the output end of the power supply (positive to positive, negative to negative)

! WARNING

- Pay attention to the input voltage of the LED strip and do not exceed this voltage.
- **NOTE:** The total power of the LED strip cannot be greater than the power supply power (preferably less than 85% of the power supply power).
- **NOTE:** Please disconnect the circuit first when connecting the light strip.

CONTROL OF RGB LED STRIP

NOTE: As the Streamline Series is powered by class 2, 24V power supplies, you will need one power supply and one controller (CNTRL-RGBCCT) for the first 20' run of LED strip. A signal amplifier (CNTRL-AMP) and additional class 2 power supply will be required for each additional 20' run of LED strip.

1. Connect color coded wires from power feed connector to output side on Controller. The output side of the controller is marked V+, R, G, B, CW, WW. The black wire on the power feed goes to the V+ terminal on the controller. CW AND WW are typically white or yellow wires.



2. Connect the input side of controller to appropriate size of 24V power supply. Use EITHER the V+, V- terminals OR the barrel socket, but not both. See our Tape Selection guide for more driver information. (website)

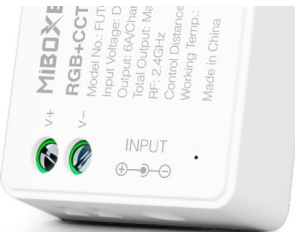

3. Connect line voltage side of power supply to line voltage.

NOTE: Line voltage connections should be carried out by a qualified electrician.

For Installations with multiple lengths of RGB/RGBW LED strip, you will need a signal amplifier (CNTRL-AMP) for each additional run as follows:

1. Follow either schematic in FIG. 1,2.
2. Connect power feed to input side of amplifier, as shown below.
3. Connect output side of power supply to "POWER +/-" feed in signal amplifier. See below.
4. Connect primary side of power supply to mains voltage.

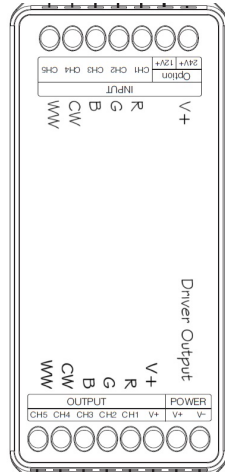

SUMMARY:

The CNTRL-AMP amplifier receives Pulse Width modulation (PWM) signal from the controller allowing you to do multiple runs from a single controller. They are powered individually by a class 2 power supply. The power supply should match the wattage of the length of LED strip you are controlling.

See also alternate wiring diagram below in CCT Adjust series which can be used for RGB.

FIG. 1.

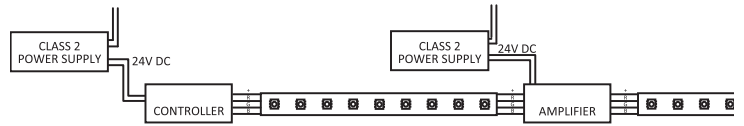
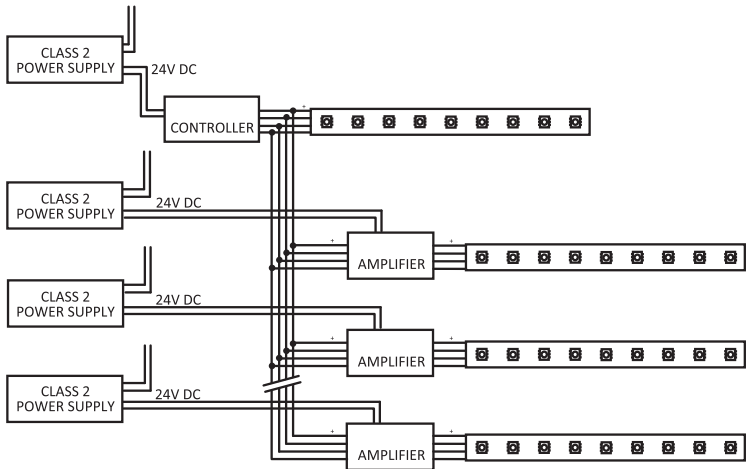
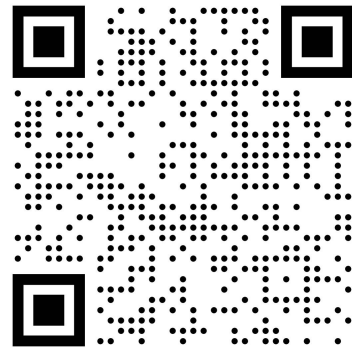

FIG. 2.



For more information on extrusions, accessories or specific LED products please use the QR code below.



CONTROL OF TUNABLE CCT LED STRIP

NOTE: As the Streamline Series tunable CCT product is powered by class 2, 24V power supplies, you will need one power supply and one controller (CNTRL-2W-CCT) for the first run of LED strip. You can run 2 lengths of this product from one controller. (MAX 10AMPS@24V)

1. Connect power feed from the strip light to the output side of the controller (CNTRL-2W-CCT) as shown below. (push dimming is optional)
2. Connect output side of driver to "POWER +/-" on the input side of the controller. See above. Ensure appropriate size of 24V power supply from list of approved power supplies.
3. Connect line voltage side of power supply to line voltage.

NOTE: Line voltage connections should be carried out by a qualified electrician.

For Installations with multiple lengths of CCT LED strip, (more than 2) you will need additional controllers. The CCT remotes, CNTRL-4Z-CCT-RWP-Y and CNTRL-4Z-CCT-RM can connect multiple Controllers. (12 Max)

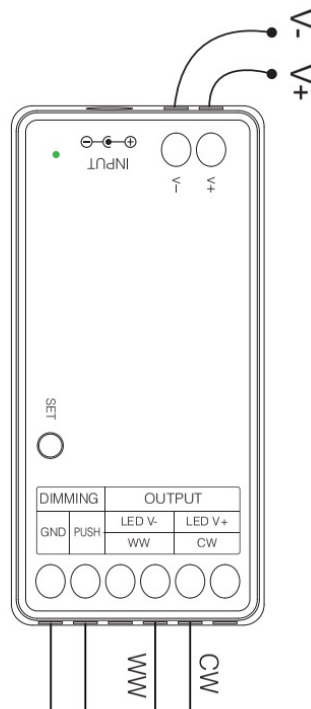

WARNING AND CAUTIONS

1. Do not operate with the flexible light tightly coiled.
2. During installation, make sure flexible light isn't receiving electricity in any manner.
3. Make sure the voltage marked on your light strip matches the power supply.
4. Do not overlap this product as the overlapping may cause the flexible light to overheat and melt or ignite.
5. Do not puncture, cut, shorten, or splice the flexible lighting.
6. Do not route flexible lighting through walls, doors, windows or any like part of the building structure. See wiring diagrams for remote power source installations.
7. Do not use if there is any damage to the light or cord insulation. Inspect periodically.
8. Do not submerge flexible light in liquids, or use the product in the vicinity of standing water or other liquids. Keep all parts of LED strip installation at least 10 feet (305 cm) from any swimming or decorative pool. Secure this flexible light using only the hangers or clips provided.
9. Do not secure this product or its cord with staples, nails, or like means that may damage the insulation.
10. Do not subject flexible lighting to continuous flexing.
11. Do not exceed the length in feet permitted by the marking.
12. Make sure to disconnect the power before adding segments.
13. Only use extension segments provided with the entire set of product.
14. To preclude the entry of water, make sure that all connections between section segments are secure.
15. Do not bend the LED strip in the horizontal plane at all. Use "T", "+", "L", or step cords instead. Maintain a minimum 2" (5.1cm) radius in the vertical plane.
16. Do not subject flexible light to over 15 lbs. of tensile force.
17. When connecting the flexible light with connectors, step cord, and the power supply (LED driver), make sure the polarity markings are correctly matched.
18. When using outdoor use portable lighting products, basic safety precautions should always be followed to reduce the risk of fire, electric shock, and personal injury, including the following:
 - a. Ground Fault Circuit Interrupter (GFCI) protection should be provided on the circuits or outlet to be used for the outdoor use of flexible lighting product. Receptacles are available having built-in GFCI protection for this measure of safety.
 - b. Use only listed outdoor extension cord from 110VAC source to LED Driver, such as type SW, SOW, STW, STOW, SJW, SJOW, SJTW, or SJTOW. This designation is marked on the wire of the extension cord.